

TCF40 Series

40 Watts

- Market leading size
- 40W in 1.5 x 3" footprint
- Convection cooled
- <0.1W No load input power
- EN55022 Level B conducted & radiated
- 50W Peak power
- 5 Year warranty

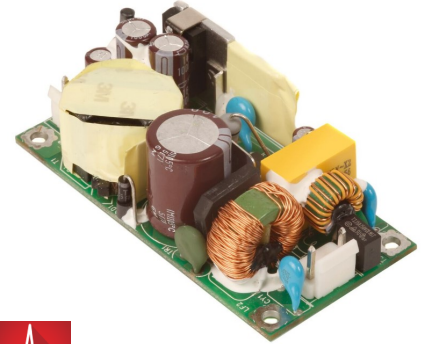

Peak Power

Dimensions:

3 x 1.5 x 0.93" (76.2 x 38.1 x 23.5mm)

The TCF40 series of ultra compact, open frame AC-DC power modules offer 40W convection cooled in a market leading 1.5" x 3" package. They are chassis mount, low noise and offer a 50W peak rating for 60 seconds. The units have a wide temperature range from 0-70°C and offer low no-load power consumption of <0.1W. Outputs are available from 5 to 48V and all come with a FiDUS 5 year warranty.

Models & Ratings

INSTALLATION ADVICE PG5

Model Number	Output Power	Output voltage	Output Current		Efficiency ⁽²⁾
			Maximum convection	Peak convection ⁽¹⁾	
TCF4005	25W	5V	5A	7A	83.5%
TCF4012	40W	12V	3.34A	4.17A	87%
TCF4015	40W	15V	2.67A	3.34A	89%
TCF4018	40W	18V	2.23A	2.78A	89%
TCF4024	40W	24V	1.67A	2.09A	90%
TCF4036	40W	36V	1.12A	1.39A	90.5%
TCF4048	40W	48V	0.84A	1.05A	91%

Notes

1. Peak for a maximum 60 seconds. Average output power must remain $\leq 40W$ ($\leq 25W$ for TCF4005)
2. At 100% load, 230VAC
3. Loom kits available. See 'Installation Advice' on pg5

Key specifications

Parameter	Minimum	Typical	Maximum	Units	Notes & Conditions
AC Input range	90		264	VAC	No derating
Operating temperature	0		70	°C	Derate linearly from 100% power at 50°C to 50% power at 70°C. See derating curve
Efficiency	>85% typical at full load, 115VAC (TCF4005: 80%)				
Dimensions	3 x 1.5 x 0.93" (76.2 x 38.1 x 23.5mm)				
EMC	EN55022 Level B conducted and radiated. EN61000-3 and EN61000-4, harmonics, flicker, Surge, EFT, ESD, conducted and radiated,				
Safety	IEC60950-1, EN60950-1, UL60950-1, CSA22.2 No 60950-1, IEC/EN 62368-1, CE				

Input					
Parameter	Minimum	Typical	Maximum	Units	Notes & Conditions
Input voltage	90		264	VAC	No derating
Input frequency	47		63	Hz	
Power factor					EN61000-3-2 class A compliant
Input current (rms)			1	A	At 115VAC
			0.5		At 230VAC max
Inrush current			<40	A	115VAC cold start at 25°C
			<80		230VAC cold start at 25°C
No load input power			<0.1	W	

Output					
Parameter	Minimum	Typical	Maximum	Units	Notes & Conditions
Output voltage	5		48	VDC	See Model & Ratings table
Set point accuracy			±5	%	
Line regulation			±1	%	
Load regulation			±3	%	
Minimum load	0			%	
Transient response			10	%	Max deviation (10mS for 0%-50% load and 50%-100% load change)
Ripple & Noise	5V output 100mV. 12V output 120mV. 15V output 150mV. 18V output 180mV. 24-48V outputs 240mV.			mV(Vp-p)	All models measured with 0.1uF ceramic and 10uF electrolytic capacitor. 20 MHz bandwidth.
Hold up time		>6		ms	At full load, 115VAC
Overload protection			180	%	
Short circuit protection					Trip and restart. Automatic recovery
Overvoltage protection	110		130	%	Latching, requires manual power reset.

General					
Parameter	Minimum	Typical	Maximum	Units	Notes & Conditions
Efficiency	>85% typical at full load, 115VAC (TCF4005: 80%)				
Isolation: Input to Output	3000			VAC	
Input to Ground	1500			VAC	
Output to Ground	500			VDC	
Switching frequency	50		60	KHz	
Power density			9.6	W/In ³	
MTBF		>150		KHrs	As per MIL-HDBK-217F, 25°C GB
Weight		74		g	

Environmental					
Parameter	Minimum	Typical	Maximum	Units	Notes & Conditions
Operating temperature	0		70	°C	Derate linearly from 100% power at 50°C to 50% power at 70°C. See derating curve
Storage temperature	-40		85	°C	
Cooling					Convection cooled
Temperature coefficient			0.05	%/°C	
Humidity	5		95	% RH	Non condensing

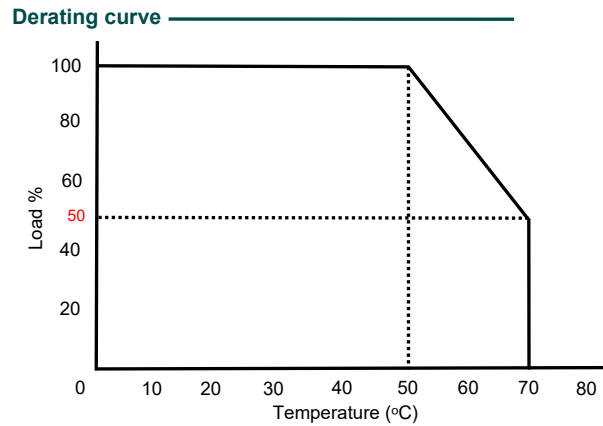

EMC: Emissions

	Standard	Test level	Criteria	Notes & Conditions
Conducted	EN55022	B		
Radiated	EN55022	B		
Harmonic current	EN61000-3-2	Class A		
Voltage flicker	EN61000-3-3			

EMC: Immunity

	Standard	Test level	Criteria	Notes & Conditions
ESD	EN61000-4-2	2	A	
Radiated	EN61000-4-3	3V/m	A	
EFT	EN61000-4-4	2	A	
Surges	EN61000-4-5	Installation Class 3	A	
Conducted	EN61000-4-6	2	A	
Magnetic Fields	EN61000-4-8	1A/m	A	

Safety Approvals

	Safety standard	Notes & Conditions
UL/CSA	UL60950-1 2nd Ed., CSA 22.2 No 60950-1 2nd Ed.	
CB	IEC60950-1 2nd Ed. IEC62368-1 2018 2nd Ed	
TUV	EN60950-1 2nd Ed.	
CE		2011/65/EU RoHS Directive and 2014/35/EU Low voltage directive
Equipment protection class		Class I

Mechanical Details

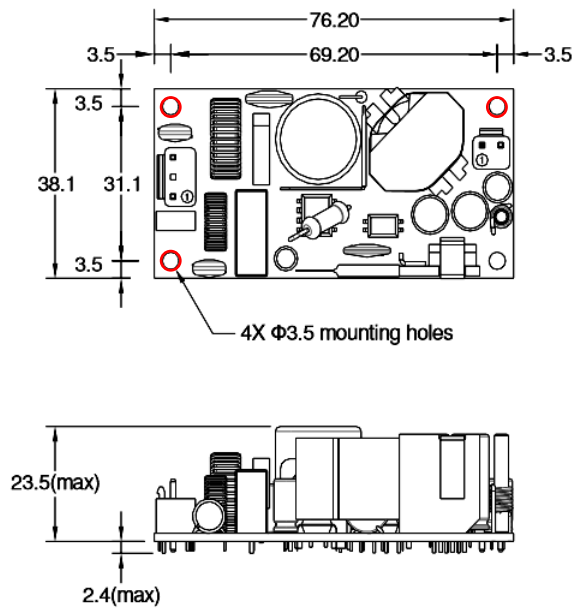

CN1: Input Connector ⁽²⁾	
Pin Connections	
Pin	Function
1	AC Line
2	AC Neutral

CN2: Output Connector ⁽³⁾	
Pin Connections	
Pin	Function
1	GND
2	+Vout

Notes

1. All dimensions shown in millimetres (mm)
2. CN1: Input connector details: JST B3P-VH-B pitch: 7.92mm mating part: JST VHR-3N or equivalent
3. CN2: Output connector details: JST B2P-VH-B pitch: 3.96mm mating part: JST VHR-2N or equivalent
4. Connect all mounting points to chassis (both the primary side and top RHS in particular) for safe class I installation and EMC performance (marked above in red)

Installation Advice

Safety

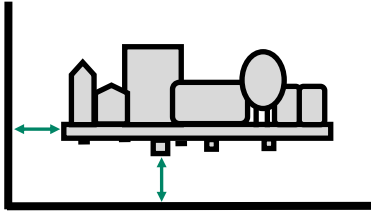

On installation customers must consider the required creepage and clearance distances between the PSU and the end-equipment enclosure. These distances vary depending on the installation class and safety standard requirements.

For **Class I** installations there should be 3-4mm between any part of the PSU and any earthed metal part of the enclosure. 3mm is acceptable for IT applications, 4mm required for medical applications. In Class I installations the PSU earth point must be connected to system safety ground.

For **Class II** installations distances may need to be increased if being installed into a surrounding metal enclosure.

Ensure consideration of components on the underside of the PCB or low lying spills when measuring clearance distances between the PSU and the end-equipment. Also top surface especially in tight enclosures such as 1U boxes. An insulation material can be used between PSU and metal if smaller gap required.

FiDUS recommends installing the PSU on 6mm stand offs typically, but check the distances.

EMC

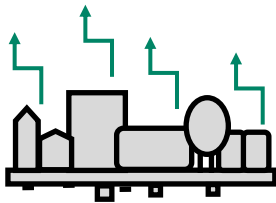

Conducted and radiated emissions compliance is a common application consideration. It is important to remember that even when using a properly filtered PSU, an application may still not achieve compliance if it is not designed to minimise emissions. That being said, there are a number of things that can be done to optimise EMC performance either as best practice, or if you are struggling for compliance:

- 1) Connect all marked EMI ground points to earth. Often these are combined with the safety earth point (in class I installations), but on some power supplies there may be additional earth tags or mounting points.
- 2) Minimise the length of input/output wiring where possible and try to maintain max distance of the conductors from the PSU, to prevent noise pick up. Avoid bundling input and output cables together. A common component to avoid placing wiring near is the PFC inductor in power factor corrected power supplies.
- 3) Apply additional filtering before the PSU input (ensure consideration of which frequencies there are issues with before selecting a filter).
- 4) When using an open frame PSU, mount the supply on a metal plate and connect EMI mounting points.
- 5) In multi circuit systems, decouple the circuits locally.
- 6) Ferrites added between the PSU and system input connector and/or the DC output cables can help in reducing radiated noise issues in systems. If seen, issues are commonly in the 30-150MHz area.

For more detailed assistance, if you still have any concerns with compliance, please get in contact with our Engineering department who are on hand to assist with any queries.

Thermal

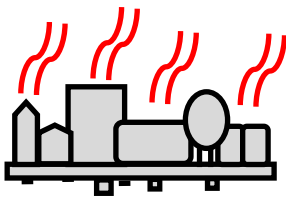

Thermal management is an important consideration when thinking about equipment service life. Electrolytic capacitors within the PSU wear with time and are typically the first end-of-life failure. Keeping the operation temperature of key components within the PSU, such as the electrolytic capacitors, as low as possible is paramount. As a general rule, for every 10°C drop in the operating temperature of the electrolytic capacitors you double their lifetime, and thus the lifetime of the power supply. When looking at thermal performance it is helpful to test under a worst-case set of conditions, to ensure component temperatures are in an acceptable range for the required service life. Then consider the impact of operational time, load and temperature profile to estimate a more realistic lifetime for your PSU.

Also, many FiDUS power supplies offer a *Peak Power* rating to provide for customers with pulsing loads. When using a peak power capability customers must consider:

- 1) Peak duration rating: the maximum length of time the peak can be drawn for
- 2) Duty cycle: the frequency with which the peak can be drawn. (e.g. 10% duty cycle, 1 second on:9 seconds off)
- 3) Average power value: datasheets will state the maximum average power acceptable with peak power PSUs. If any of these elements are exceeded the supply may overheat, with performance and lifetime suffering as a result.

Connectivity

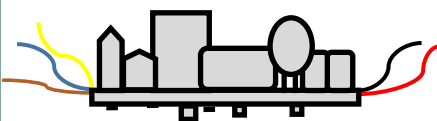

All FiDUS Power engineering samples requested will arrive with a free of charge loom kit for ease of testing.

The loom kit connects to the input/output terminals of the PSU and provides the customer with bare wire ends to connect with.

The loom kits can also prove advantageous for ease of installation in production. Please contact sales if you are interested in including the loom kit in your quotation. Alternatively the input/output connector and mating part details can be found in the attached table.

	Part Number	Mating Part Number
Input	JST B3P-VH-B	JST VHR-3N
Output	JST B2P-VH-B	JST VHR-4N
Loom Kit	TCF40 LK	